



VARITRONIX

VL-PS-COG-MT280Q-03 REV. A

(COG-MT280Q)

DEC/2007

PAGE 1 OF 18

DOCUMENT NUMBER AND REVISION

VL-PS-COG-MT280Q-03 REV. A

(COG-MT280Q)



DOCUMENT TITLE:

PRELIMINARY SPECIFICATION

OF

LCD MODULE TYPE

MODEL NUMBER: COG-MT280Q-03

DEPARTMENT	NAME	SIGNATURE	DATE
PREPARED BY	PHILIP CHENG		2007/12/04
CHECKED BY	RICKY WONG		2007/12/4
APPROVED BY	CYRUS CHEUNG		2007/12/4

DISTRIBUTION LIST: MARKETING



DOCUMENT REVISION HISTORY 1:

DOCUMENT REVISION FROM TO	DATE	DESCRIPTION	CHANGED BY	CHECKED BY
A	2007.12.04	First Release.	PHILIP CHENG	RICKY WONG

CONTENTS

	<u>Page No.</u>
1. GENERAL DESCRIPTION	4
2. MECHANICAL SPECIFICATIONS	4
3. INTERFACE SIGNALS	7
4. ABSOLUTE MAXIMUM RATINGS	9
4.1 ELECTRICAL MAXIMUM RATINGS-FOR IC ONLY	9
4.2 ENVIRONMENTAL CONDITION	9
5. ELECTRICAL SPECIFICATIONS	10
5.1 TYPICAL ELECTRICAL CHARACTERISTICS	10
5.2 TIMING SPECIFICATIONS	11
5.3 POWER SUPPLY INSTRUCTION SETTING FOR R61505U	14
6. OPTICAL CHARACTERISTICS	16
6.1 SPECIFICATION	16
7. REMARK	18

VARITRONIX LIMITED

**Preliminary Specification
 of
 LCD Module Type
 Model No.: COG-MT280Q-03**

1. General Description

- 2.8", 240 x 3 x 320 dots, positive, transmissive, mono TFT LCD module.
- Anti-glare front polarizer.
- Viewing angle: 12 o'clock.
- Driving IC: RENESAS' R61505U1 or equivalent liquid crystal controller driver for a-Si TFT panel.
- 80-system 8-bit interface or clock synchronous serial interface.
- Supply voltage (logic regulator & interface I/O), VCC: 2.8V.
- FPC connection.

2. Mechanical Specifications

The mechanical detail is shown in Fig. 1 and summarized in Table 1 below.

Table 1

Parameter		Specifications	Unit
Outline dimensions		48.6(W) x 67.8(H) x 1.67(D) (Exclude FPC, component area & bending area. Include LCD end-seal.)	mm
Mono TFT 240x3x320	Active area	43.2(W) x 57.6(H)	mm
	Display format	240 x 3 x 320	dots
	Dot pitch	0.06(W) x 0.18(H) (or 0.18(W)(3 successive horizontal dots) x 0.18(H))	mm
Weight		TBD	grams

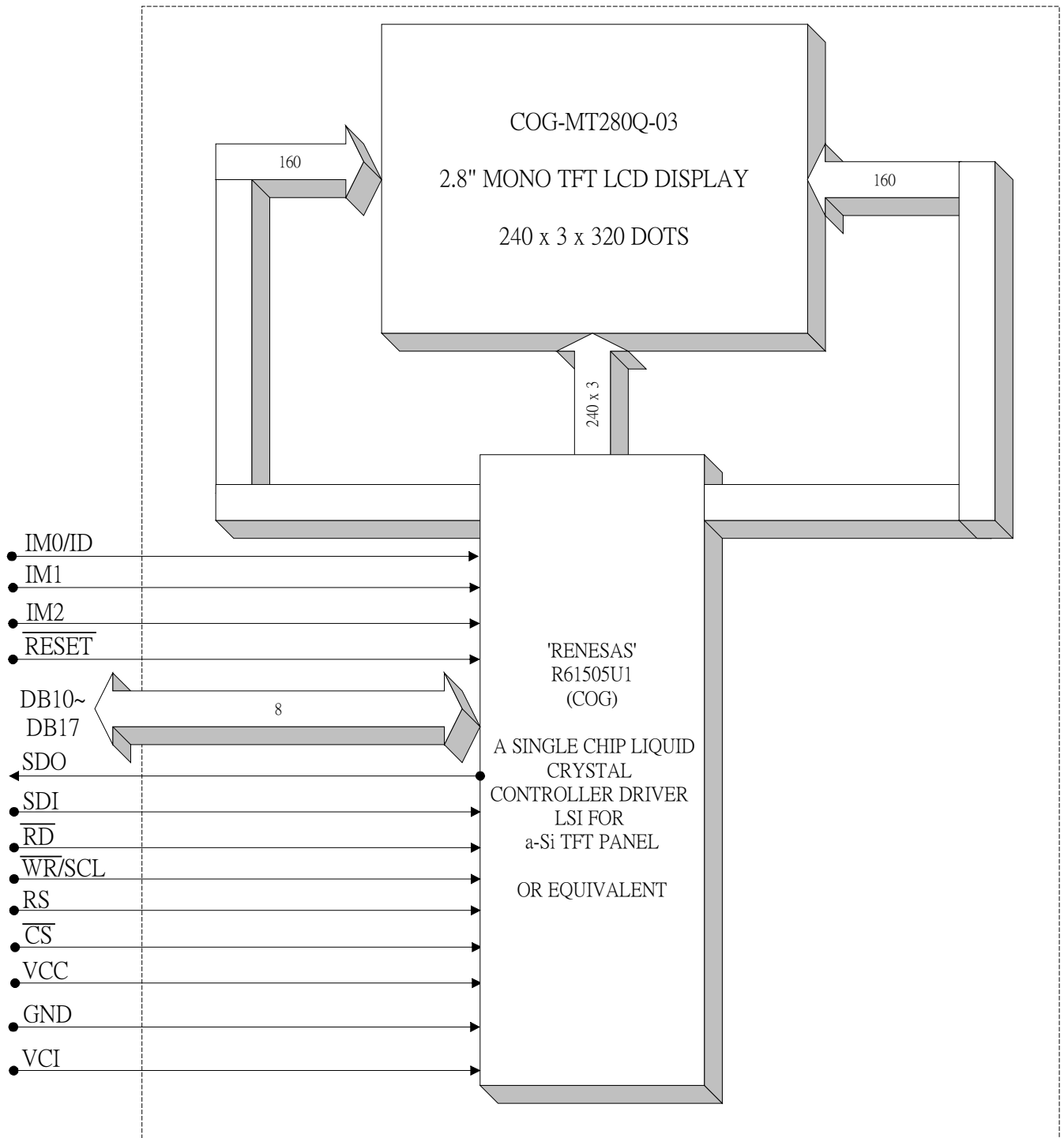

Figure 2: Block Diagram

3. Interface signals

Table 2(a): Pin assignment

Pin No.	Symbol	Description
1	A	No connection.
2	K	No connection.
3	VCI	Power supply to the liquid crystal power supply analog circuit. Connect to an external power supply of 2.5V ~ 3.3V.
4	GND	GND (IOGND or AGND or GND).
5	GND	Ground for the interface pins, analog ground and internal logic ground. GND=0V.
6	VCC	VCC(IOVCC). VCC: Power supply to internal logic regulator circuit: VCC=2.5V~3.3V. IOVCC: Power supply to the interface pins: $\overline{\text{RESET}}$, $\overline{\text{CS}}$, $\overline{\text{WR/SCL}}$, $\overline{\text{RD}}$, RS, and DB17-10. In case of COG, connect to VCC on the FPC if IOVCC=VCC, to prevent noise.
7	$\overline{\text{CS}}$	$\overline{\text{CS}}$ (CS*). Chip select signal. Amplitude: IOVCC-IOGND. Low: the R61505U is selected and accessible. High: the R61505U is not selected and not accessible.
8	RS	Register select signal. Amplitude: IOVCC-IOGND. Low: select Index or status register. High: select control register.
9	$\overline{\text{WR/SCL}}$	$\overline{\text{WR/SCL}}$ (WR*/SCL). Write strobe signal in 80-system bus interface operation and enables write operation when $\overline{\text{WR}}$ is low. Synchronous clock signal (SCL) in serial interface operation. Amplitude: IOVCC-IOGND.
10	$\overline{\text{RD}}$	$\overline{\text{RD}}$ (RD*). Read strobe signal in 80-system bus interface operation and enables read operation when $\overline{\text{RD}}$ is low. Amplitude: IOVCC-IOGND.
11	SDI	Serial data input (SDI) pin in serial interface operation. The data is inputted on the rising edge of the SCL signal. Amplitude: IOVCC-IOGND.
12	SDO	Serial data output (SDO) pin in serial interface operation. The data is outputted on the falling edge of the SCL signal. Amplitude: IOVCC-IOGND.
13	DB10	8-bit parallel bi-directional data bus for 80-system interface operation (Amplitude: IOVCC-IOGND).
14	DB11	
15	DB12	
16	DB13	
17	DB14	
18	DB15	
19	DB16	
20	DB17	
21	$\overline{\text{RESET}}$	$\overline{\text{RESET}}$ (RESET*). Reset signal. Initializes the R61505U when it is low. Make sure to execute a power-on reset when turning on power supply (IOVCC-IOGND amplitude signal).

Table 2(b): Pin assignment

Pin No.	Symbol	Description					
22	IM2	Select a mode to interface to an MPU. In serial interface operation, the IM0 pin is used to set the ID bit of device code.					
		IM2	IM1	IM0/ID	Interface mode	DB pin	Colors
		0	0	0	Setting disabled	-	-
23	IM1	0	0	1	Setting disabled	-	-
		0	1	0	80-system, 16-bit interface	DB17~10, DB8-1	262,144 (65,536 colors in one transfer mode)
		0	1	1	80-system, 8-bit interface	DB17~10	262,144 (65,536 colors in two transfer mode)
24	IM0/ID	1	0	*(ID)	Clock synchronous serial interface	-	65,536
		1	1	0	Setting disabled	-	-
		1	1	1	Setting disabled	-	-

4. Absolute Maximum Ratings

4.1 Electrical Maximum Ratings-For IC Only

Table 3

Parameter	Symbol	Min.	Max.	Unit	Note
Power supply voltage (VCC)	VCC-GND	-0.3	+4.6	V	1,2
Power supply voltage (IOVCC)	IOVCC-GND	-0.3	+4.6	V	1,2
Power supply voltage (VCI)	VCI-AGND	-0.3	+4.6	V	1,3
Power supply voltage (AGND-VGL)	AGND-VGL	-0.3	+13.0	V	1,4
Power supply voltage (VGH-VGL)	VGH-VGL	-0.3	+30.0	V	1
Input voltage	Vt	-0.3	IOVCC+0.3	V	1

Note 1. If the R61505U is used beyond the absolute maximum ratings, the LSI may be permanently damaged. It is strongly recommended to use the LSI under the condition within the electrical characteristics in normal operation. If exposed to the condition not within the electrical characteristics, it may affect the reliability of the device

2. Make sure $VCC(\text{high}) \geq GND(\text{low})$, $IOVCC(\text{high}) \geq IOGND(\text{low})$.
3. Make sure $VCI(\text{high}) \geq AGND(\text{low})$.
4. Make sure $AGND(\text{high}) \geq VGL(\text{low})$.

4.2 Environmental Condition

Table 4

Item	Operating temperature (Topr)		Storage temperature (Tstg) (Note 1)		Remark
	Min.	Max.	Min.	Max.	
Ambient temperature	-30°C	+85°C	-40°C	+90°C	Dry

Note 1: Product cannot sustain at extreme storage conditions for long time.

5. Electrical Specifications

5.1 Typical Electrical Characteristics

At $T_a = 25\text{ }^\circ\text{C}$, $V_{CC}=2.5\text{V}\sim 3.3\text{V}$, $GND=0\text{V}$.

Table 5

Parameter	Symbol	Conditions	Min.	Typ.	Max.	Unit	Remark
Supply voltage (logic regulator & interface I/O)	VCC (IOVCC)		2.5	2.8	3.3	V	
Supply voltage (liquid crystal analog circuit)	VCI		2.5	-	3.3	V	
TFT gate ON voltage	VGH		-	TBD	-	V	
TFT gate OFF voltage	VGL		-	TBD	-	V	
TFT common electrode voltage	VcomH		-	TBD	-	V	Note 2
	VcomL		-	TBD	-	V	
Black of Video Low Voltage	VLB		-	TBD	-	V	Note 3
Black of Video High Voltage	VHB		-	TBD	-	V	
White of Video Low Voltage	VLW		-	TBD	-	V	
White of Video High Voltage	VHW		-	TBD	-	V	
Input signal voltage	V_{IH}	"H" level, $V_{CC}=IOVCC$ $=2.5\text{V to }3.3\text{V}$	$0.80 \times V_{CC}$	-	VCC	V	
	V_{IL}	"L" level $V_{CC}=IOVCC$ $=2.5\text{V to }3.3\text{V}$	-0.3	-	$0.20 \times V_{CC}$	V	
Supply current (logic regulator & interface I/O)	ICC	$V_{CC}=2.8\text{V}$	-	TBD	-	mA	
Supply current (liquid crystal analog circuit)	ICI	$V_{CI}=TBD$	-	TBD	-	mA	

Note (1): There is tolerance in optimum LCD driving voltage during production and it will be within the specified range.

Note (2): Vcom must be adjusted to optimize display quality.

Note (3):

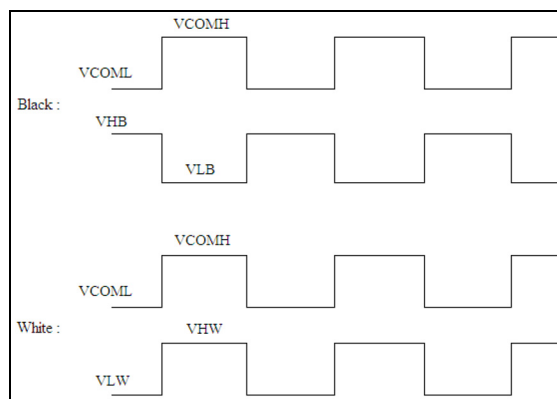

Figure 3

5.2 Timing Specifications

5.2.1 80-System Bus Interface Timing Characteristics (8-bit interface) for R61505U

At $T_a = -30^{\circ}\text{C}$ to 85°C , $V_{CC} = I_{OVCC} = 2.50\text{V} \sim 3.30\text{V}$.

Table 6: Normal Write Function (HWM=0)/ High-speed Write Function (HWM=1)

Item	Symbol	Unit	Min.	Typ.	Max.
Bus cycle time	Write	t _{CYCW}	ns	70	—
	Read	t _{CYCR}	ns	450	—
Write low-level pulse width	PWLW	ns	30	—	—
Read low-level pulse width	PWLR	ns	170	—	—
Write high-level pulse width	PWHW	ns	25	—	—
Read high-level pulse width	PWHR	ns	250	—	—
Write / Read rise/ fall time	t _{WRr} , t _{WRf}	ns	—	—	25
Setup time	Write (RS to CS*, WR*)	t _{AS}	ns	0	—
	Read (RS to CS*, RD*)		ns	10	—
Address hold time	t _{AH}	ns	2	—	—
Write data setup time	t _{DSW}	ns	25	—	—
Write data hold time	t _H	ns	10	—	—
Read data delay time	t _{DDR}	ns	—	—	150
Read data hold time	t _{DHR}	ns	5	—	—

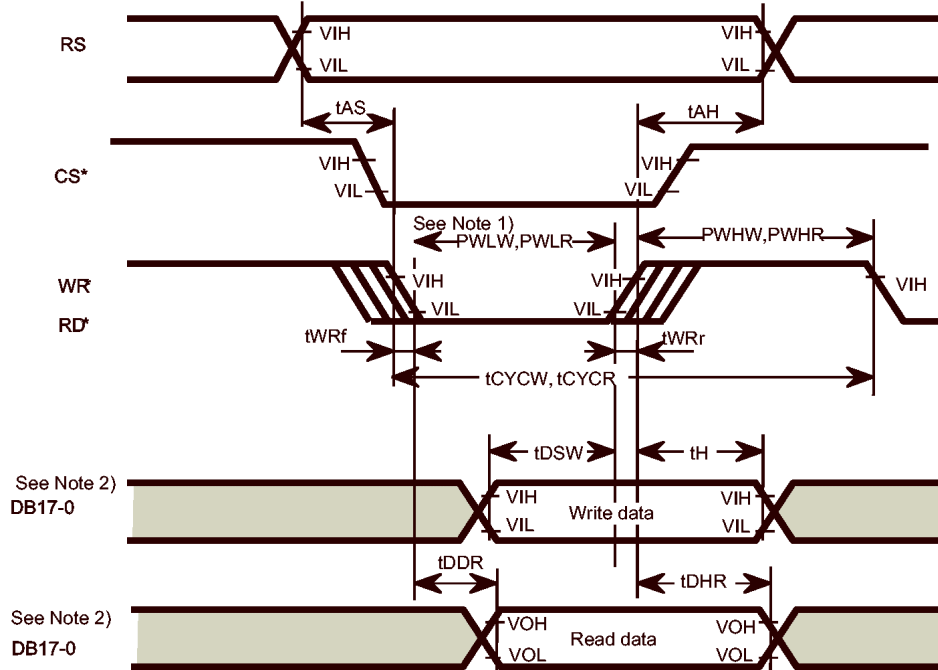

Note 1) PWLW and PWLR are defined by the overlap period when CS* is "Low" and WR* or RD* is "Low".
Note 2) Unused DB pins must be fixed at "IOVcc 1" or "IOGND 1".

Figure 4: 80-System Bus Interface

5.2.2 Clock-synchronized Serial Interface Timing Characteristics

At Ta = -30°C to 85°C, VCC = IOVCC=2.5V to 3.3V.

Table 7: Normal Write Function (HWM=0), High-speed Write Function (HWM=1)

Item		Symbol	Unit	Min.	Typ.	Max.
Serial clock cycle time	Write (receive)	tSCYC	ns	100	—	20,000
	Read (transmitted)	tSCYC	ns	350	—	20,000
Serial clock high-level width	Write (receive)	tSCH	ns	40	—	—
	Read (transmitted)	tSCH	ns	150	—	—
Serial clock low-level width	Write (receive)	tSCL	ns	40	—	—
	Read (transmitted)	tSCL	ns	150	—	—
Serial clock rise/fall time		tscr, tscf	ns	—	—	20
Chip select setup time		tCSU	ns	20	—	—
Chip select hold time		tCH	ns	60	—	—
Serial input data setup time		tSISU	ns	30	—	—
Serial input data hold time		tSISH	ns	30	—	—
Serial output data delay time		tSOD	ns	—	—	130
Serial output data hold time		tSOH	ns	5	—	—

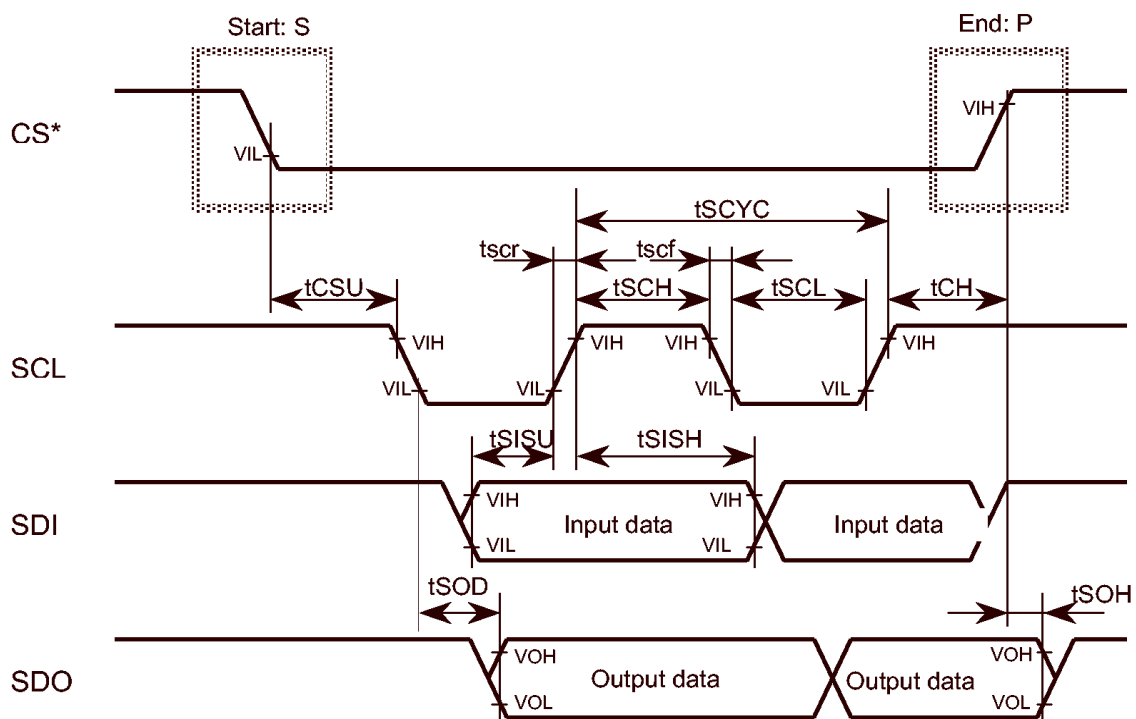

Figure 5: Clock Synchronous Serial Interface

5.2.3 Reset Timing Characteristics for R61505U

At $T_a = -30^{\circ}\text{C}$ to $+85^{\circ}\text{C}$, $V_{CC} = I_{OVCC} = 2.50\text{V} \sim 3.30\text{V}$.

Table 8

Item	Symbol	Unit	Min.	Typ.	Max.
Reset low-level width	tRES	ms	1	—	—
Reset rise time	trRES	μs	—	—	10



Figure 6: Reset Operation

5.3 Power Supply Instruction Setting For R61505U

The following are the sequences for setting power supply ON/OFF instructions. Set power supply ON/OFF instructions according to the following sequences in Display ON/OFF, Sleep set/exit sequences.

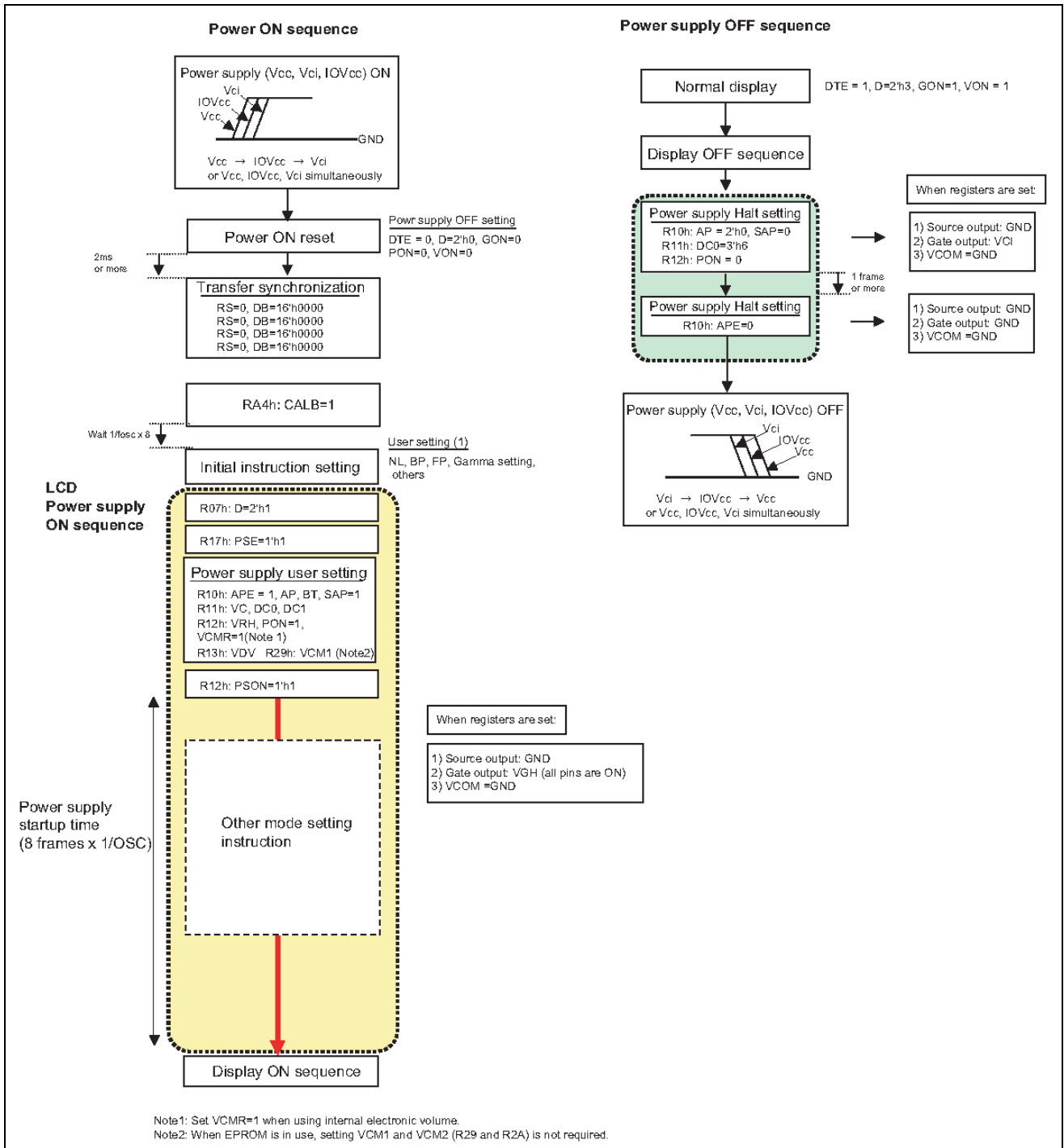

Figure 7

Notes to Power Supply ON sequence

1. When voltages do not rise in the order of VCC, IOVCC and then VCI, changing the order to IOVCC, VCC and then VCI will not lead to trouble such as latchup or the die go broken. Please read below carefully in operating the R61505U.

2. Notes

If there is a time lag between IOVCC and VCC inputs when inputting them in IOVCC-first order, the R61505U's bus is unstable until VCC is inputted. The die may become "output" status in this case. Do not send or receive data before power supply input is completed.

3. Command input timing

Following flow chart shows power supply input to command input.

Wait 1ms or more as power on reset and display off period after inputting IOVCC, VCC and VCI.

Then wait another 10ms or more until internal operation stabilizes. And then, start inputting commands.(Waiting time: 11ms or more altogether).

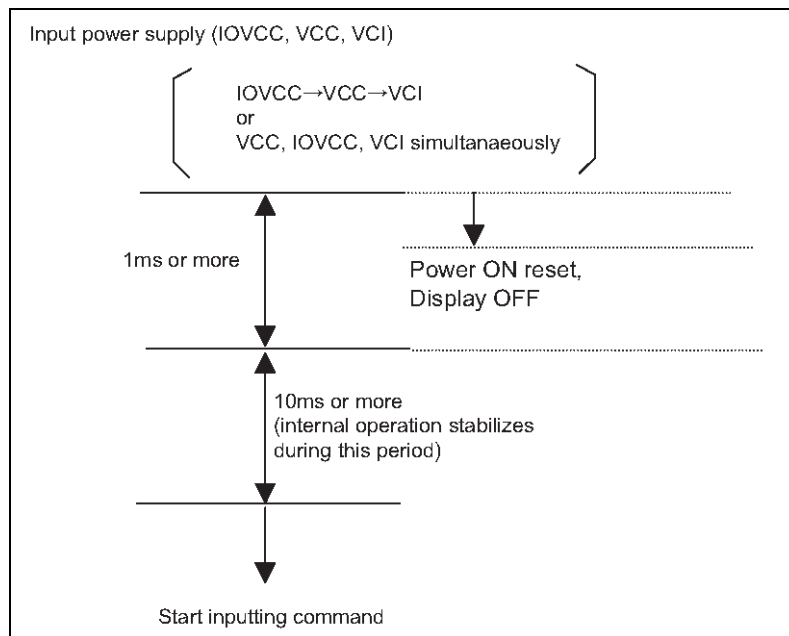

Figure 8: (when power supply input sequence is changed)

6. Optical Characteristics

6.1 Specification

Table 9

(Ta=25°C)

Item	Symbol	Condition	Values			Units	Remarks	
			Min	Typ	Max			
Viewing Angle	Horizontal	$\text{CR} \geq \text{TBD}$	-	TBD	-	deg	Note 1	
	Vertical		$\phi 1$ (6 o'clock)	-	TBD			-
			$\phi 2$ (12 o'clock)	-	TBD			-
Contrast Ratio (@25°C)	CR	Normal view	-	TBD	-	-	Note 2	
		12 o'clock	-	TBD	-	-		
Response time	Rise	$\theta=0^\circ, \phi=0^\circ$	-	TBD	-	ms	Note 3	
	Fall		-	TBD	-			
Transmission Ratio	T	$\theta=0^\circ, \phi=0^\circ$	-	TBD	-	%		

Note 1: The definitions of viewing angles

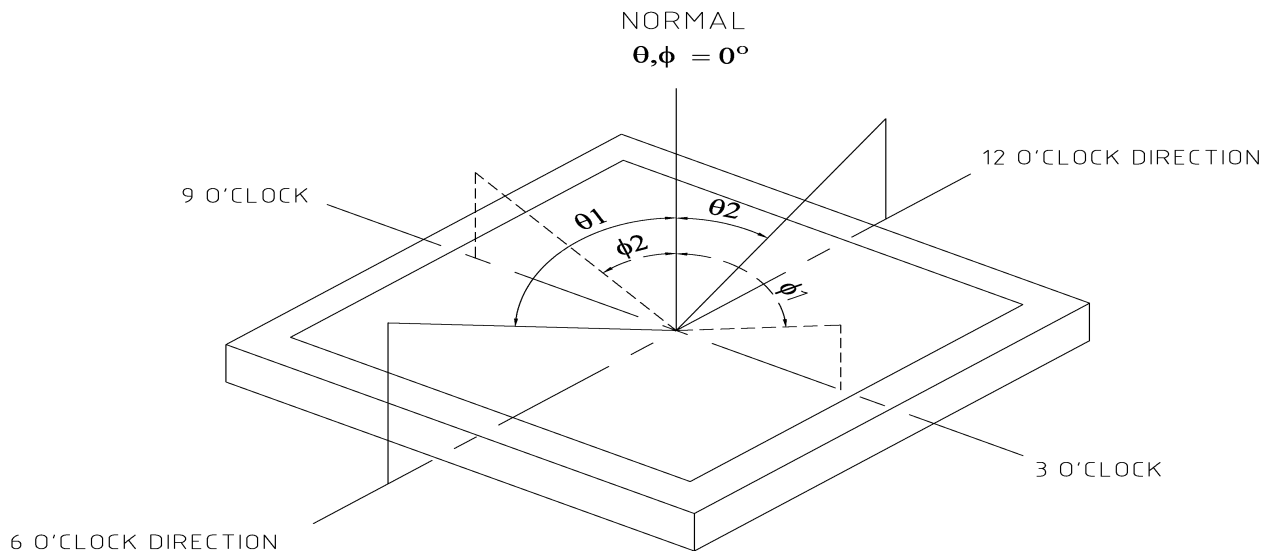

Figure 9

Note 2:

$$\text{CR} = \frac{\text{Luminance when Testing point is White}}{\text{Luminance when Testing point is Black}}$$

Contrast ratio is measured in optimum common electrode voltage.

Note 3: The definition of response time:

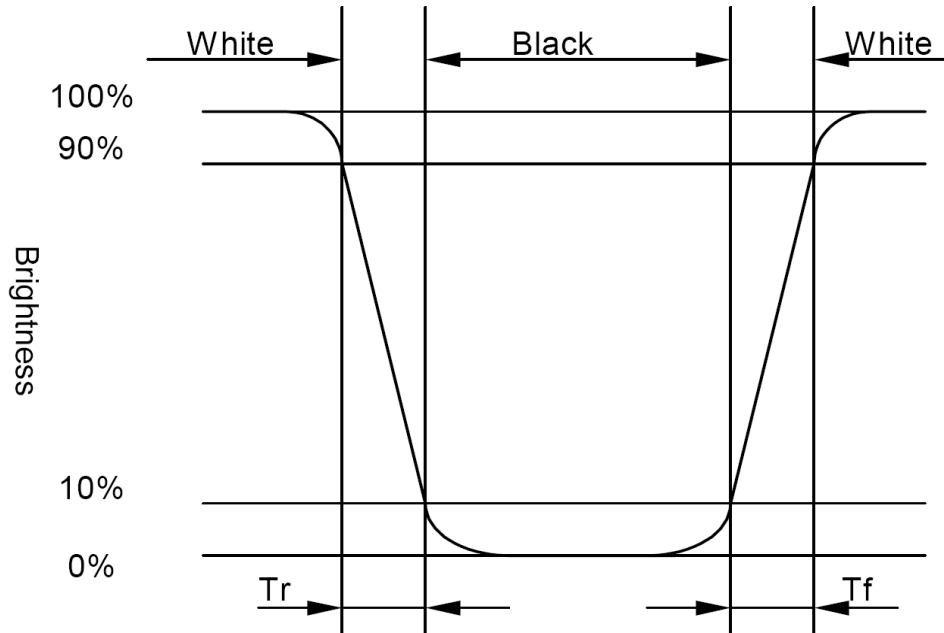

Figure 10

7. Remark

HANDLING LCD AND LCD MODULES

1. Liquid Crystal Display (LCD)

LCD is made up of glass, organic sealant, organic fluid and polymer based polarizers. The following precautions should be taken when handling:

- (1) Keep the temperature within range for use and storage. Excessive temperature and humidity could cause polarization degradation, polarizer peel-off or bubble generation. When storage for a long period over 40° C is required, the relative humidity should be kept below 60%.
- (2) Do not contact the exposed polarizers with anything harder than an HB pencil lead. To clean dust off the display surface, wipe gently with cotton, chamois or other soft material soaked in petroleum benzin. Never scrub hard.
- (3) Varitronix does not responsible for any polarizer defect after the protective film has been removed from the display
- (4) Wipe off saliva or water drops immediately. Contact with water over a long period of time may cause polarizer deformation or color fading, while an active LCD with water condensation on its surface will cause corrosion of ITO electrodes.
- (5) PETROLEUM BENZIN is recommended to remove adhesives used to attach front/rear polarizers and reflectors, while chemicals like acetone, toluene, ethanol and isopropyl alcohol will cause damage to the polarizer. Avoid oil and fats. Avoid lacquer and epoxies which might contain solvents and hardeners to cause electrode erosion. Some solvents will also soften the epoxy covering the DIL pins and thereby weakening the adhesion of the epoxy on glass. This will cause the exposed electrodes to erode electrochemically when operating in high humidity and condensing environment.
- (6) Glass can be easily chipped or cracked from rough handling, especially at corners and edges.
- (7) Do not drive LCD with DC voltage.
- (8) When soldering DIL pins, avoid excessive heat and keep soldering temperature between 260°C to 300°C for no more than 5 seconds. Never use wave or reflow soldering.

2. Liquid Crystal Display Modules (MDL)

2.1 Mechanical Considerations

MDL's are assembled and adjusted with a high degree of precision. Avoid excessive shocks and do not make any alterations or modifications. The following should be noted.

- (1) Do not tamper in any way with the tabs on the metal frame.
- (2) Do not modify the PCB by drilling extra holes, changing its outline, moving its components or modifying its pattern.
- (3) Do not touch the elastomer connector (conductive rubber), especially when inserting an EL panel.

LIMITED WARRANTY

VARITRONIX LCDs and modules are not consumer products, but may be incorporated by VARITRONIX's customers into consumer products or components thereof. VARITRONIX does not warrant that its LCDs and components are fit for any such particular purpose.

1. The liability of VARITRONIX is limited to repair or replacement on the terms set forth below. VARITRONIX will not be responsible for any subsequent or consequential events or injury or damage to any personnel or user including third party personnel and/or user.

Unless otherwise agreed in writing between VARITRONIX and the customer, VARITRONIX will only replace or repair any of its LCD which is found defective electrically or visually when inspected in

IMPORTANT NOTICE

The information presented in this document has been carefully checked and is believed to be accurate, however, no responsibility is assumed for inaccuracies. VARITRONIX reserves the right to make changes to any specifications without further notice for performance, reliability, production technique and other considerations. VARITRONIX does not assume any liability arising out of the application or use of products herein. Please see Limited Warranty in the previous section.

- (4) When mounting a MDL make sure that the PCB is not under any stress such as bending or twisting. Elastomer contacts are very delicate and missing pixels could result from slight dislocation of any of the elements.
- (5) Avoid pressing on the metal bezel, otherwise the elastomer connector could be deformed and lose contact, resulting in missing pixels.
- (6) If FPCA need to be bent, please refer the suggested bending area on the specification. The stiffener and component area on FPC/FPC/COF must not be bent during or after assembly (Note: for those models with FPC/FPC/COF +stiffener).
- (7) Sharp bending should be avoided on FPC to prevent track cracking.

2.2 Static Electricity

MDL contains CMOS LSI's and the same precaution for such devices should apply, namely:

- (1) The operator should be grounded whenever he comes into contact with the module. Never touch any of the conductive parts such as the LSI pads, the copper leads on the PCB and the interface terminals with any part of the human body.
- (2) The modules should be kept in antistatic bags or other containers resistant to static for storage.
- (3) Only properly grounded soldering irons should be used.
- (4) If an electric screwdriver is used it should be well grounded and shielded from commutator sparks.
- (5) The normal static prevention measures should be observed for work clothes and working benches; for the latter conductive (rubber) mat is recommended.
- (6) Since dry air is inductive to statics, a relative humidity of 50 - 60% is recommended.

2.3 Soldering

- (1) Solder only to the I/O terminals.
- (2) Use only soldering irons with proper grounding and no leakage.
- (3) Soldering temperature is 280°C ± 10°C .
- (4) Soldering time: 3 to 4 seconds.
- (5) Use eutectic solder with resin flux fill.
- (6) If flux is used, the LCD surface should be covered to avoid flux spatters. Flux residue should be removed afterwards.
- (7) Use proper de-soldering methods (e.g. suction type desoldering irons) to remove lead wires from the I/O terminals when necessary. Do not repeat the soldering/ desoldering process more than three times as the pads and plated through holes may be damaged.

2.4 Label

Identification labels will be stuck on the module without

obstructing the viewing area of display.

3. Operation

- (1) The viewing angle can be adjusted by varying the LCD driving voltage V_0 .
- (2) Driving voltage should be kept within specified range, excess voltage shortens display life.
- (3) Response time increases with decrease in temperature.
- (4) Display may turn black or dark Blue at temperatures above its operational range; this is however not destructive and the display will return to normal once the temperature falls back to range.
- (5) Mechanical disturbance during operation (such as pressing on the viewing area) may cause the segments to appear "fractured". They will recover once the display is turned off.
- (6) Condensation at terminals will cause malfunction and possible electrochemical reaction. Relative humidity of the environment should therefore be kept below 60%.
- (7) Display performance may vary out of viewing area. If there is any special requirement on performance out of viewing area, please consult Varitronix.

4. Storage and Reliability

- (1) LCD's should be kept in sealed polyethylene bags while MDL's should use antistatic ones. If properly sealed, there is no need for desiccant.
- (2) Store in dark places and do not expose to sunlight or fluorescent light. Keep the temperature between 0°C and 35°C and the relative humidity low. Please consult VARITRONIX for other storage requirements.
- (3) Water condensation will affect reliability performance of the display and is not allowed.
- (4) Semi-conductor device on the display is sensitive to light and should be protected properly.
- (5) Power up/down sequence.
 - a) Power Up: in general, LCD supply voltage, V_0 must be supplied after logic voltage, VDD becomes steady. Please refer to related IC data sheet for details.
 - b) Power Down: in general, LCD supply voltage, V_0 must be removed before logic voltage, VDD turns off. Please refer to related IC data sheet for details.

5. Safety

If any fluid leaks out of a damaged glass cell, wash off any human part that comes into contact with soap and water. Never swallow the fluid. The toxicity is extremely low but caution should be exercised at all times.

accordance with VARITRONIX LCD Acceptance Standards (copies available on request), for a period of one year from the date of shipment. Confirmation of such date shall be based on freight documents.

2. No warranty can be granted if any of the precautions stated in HANDLING LCD and LCD Modules above have been disregarded. Broken glass, scratches on polarizers, mechanical damages as well as defects that are caused by accelerated environmental tests are excluded from warranty.
3. In returning the LCD and Modules, they must be properly packaged and there should be detailed description of the failures or defects.

"Varitronix Limited reserves the right to change this specification."

Tel:(852) 2197-6000

Fax:(852) 2343-9555.

URL:<http://www.varitronix.com>

- END -